

Overhead Stirrer

Elevate Stirring with OHS

Discover celerity, emulsion and precision



Product Features



Safety

Built-in overload, overcurrent and over temperature safety feature to ensure complete safety, IP 54/ 42 class compliant



Advanced Stirring Control

Smart Control Stirring feature to ensure constant stirring even in changing viscosity



Enhanced Mixing Efficiency

CW & CCW motion for efficient and thorough mixing

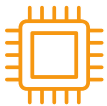

Advanced Control and Performance

Microprocessor controlled for efficient performance even under high load



Motor and Performance

Brushless DC motor delivers quiet performance and a maintenance-free long life



Automatic Restart and Continuity

In case of power failure, the Power Intermittent mode starts the device automatically as soon as power is restored and runs for the remaining left time





OHS15
(15Ncm, 20L, 1000 RPM)
8000 mpas



OHS20
(20Ncm, 25L, 2000 RPM)
10,000 mpas



OHS40
(40Ncm, 40L, 1000 RPM)
30,000 mpas



OHS50
(50Ncm, 50L, 2000 RPM)
30,000 mpas



OHS75
(75Ncm, 75L, 2000 RPM)
50,000 mpas



OHS100
(100Ncm, 100L, 1300 RPM)
70,000 mpas

*All the parameters tested with H2O

Impellers

Propeller Impeller

Standard stirring element for general mixing applications. It creates local shearing forces and axial flow in the vessel
Liquid - Liquid mixing operations



Flow Type	Diameter	Blade Size	Dia (mm)	Length (mm)	Shaft Dia (mm)	Max. RPM	Item Code
Axial (Propeller Impeller)	50	50x8	50	550	10	2000	LQLEOHA5008550PIA0
Axial (Propeller Impeller)	100	100x15	100	550	10	800	LQLEOHA10015550PI0
Axial (Propeller Impeller)	130	130x15	130	800	10	600	LQLEOHA13015800PI0

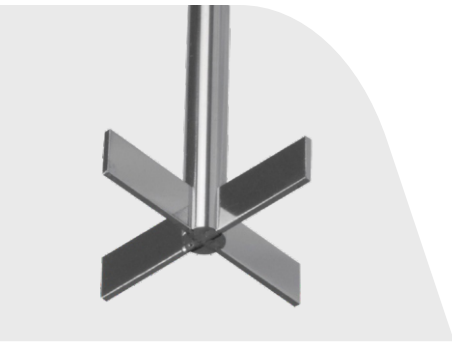

Cross Welded Impeller

The cross-welded impeller is designed for robust and efficient mixing. It creates high shearing forces and radial flow within the vessel, ensuring thorough and uniform mixing throughout the process
Viscous Liquids- Solid powder mixing in liquids

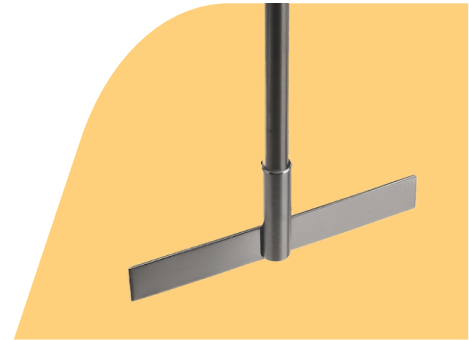

Straight B Impeller

It's an advanced stirring element designed for demanding mixing applications. generates both radial and axial flow within the vessel. Minimizing dead zones and maximizing shear forces
Liquid - Liquid mixing

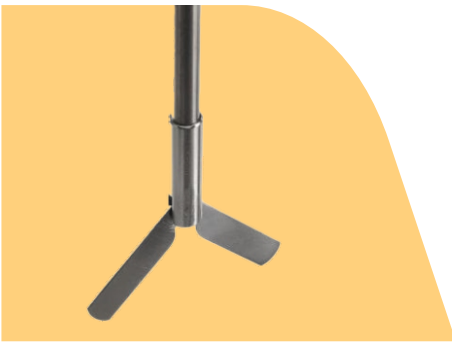

Collapsible B Impeller

Versatile stirring element designed for mixing in vessels with narrow openings. This impeller is ideal for use in containers where access is limited and can be easily inserted and removed. Liquid to liquid mixing
Low viscous - High volumes

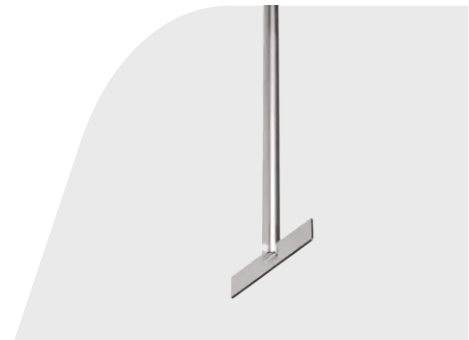

Pivoting B Impeller

Specialized stirring element designed for versatile mixing effective shearing forces and radial flow within the vessel
Liquid - Liquid mixing

Flow Type	Diameter	Blade Size	Dia (mm)	Length (mm)	Shaft Dia (mm)	Max. RPM	Item Code
Radial (Cross Welded)	50	50x12	50	550	10	2000	LQLEOHA5012550CW10
Radial (Straight B)	35	35x12	35	550	10	2000	LQLEOHA3512550SB10
Radial (Straight B)	50	50x12	50	550	10	2000	LQ LEOHA5012550SB10
Radial (Pivoting B)	60	60x15	60	550	10	2000	LQLEOHA6015550PB10
Radial (Collapsible B)	80	80x10	80	550	10	1500	LQLEOHA8010550CB11



Square B Impeller

Standard stirring element for general mixing applications. It creates local shearing forces and tangential flow in the vessel. The square blade design ensures efficient and thorough mixing, making it ideal for handling a wide range of viscosities and ensuring uniform product consistency. High volumes - Liquid stirring

Anchor B Impeller

It creates local shearing forces and radial flow in the vessel. The anchor-shaped design ensures effective mixing along the vessel walls, making it ideal for high-viscosity fluids and preventing sedimentation. Standard stirring element for general mixing applications
High volumes, like Slurry mixing

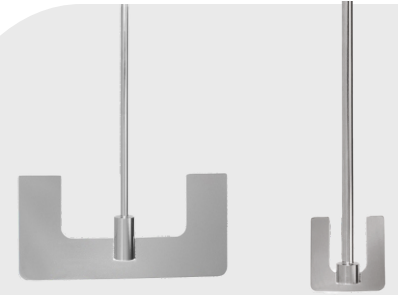

Paddle B Impeller

Paddle agitators consist of two flat paddle-shaped impeller blades extending to reach the tank walls. They are used if no extensive axial and radial flow is required. These impellers can produce a laminar low shear flow and are used for low viscosity liquid mixing, crystallization, dissolution, and heat transfer
High volumes - Biomass

Flow Type	Diameter	Blade Size	Dia (mm)	Length (mm)	Shaft Dia (mm)	Max. RPM	Item Code
Tangential (Square B)	38	38x38	38	550	10	1000	LQEOHA3838550SBI1
Tangential (Square B)	70	70x70	70	800	10	600	LQLEOHA7070800SBI1
Tangential(Anchor B)	45	45x45	45	550	10	800	LQLEOHA4545500ABIO
Tangential (Anchor B)	90	90x80	90	800	10	600	LQLEOHA9080800ABIO
Tangential (Paddle B)	70	70x70	70	550	10	800	LQLEOHA7070550PBI0
Tangential (Paddle B)	70	70x70	70	800	10	600	LQLEOHA7070800PBI0
Tangential (Paddle B)	70	70x80	70	550	10	800	LQLEOHA7080550PBI0
Tangential (Paddle B)	70	70x80	70	800	10	600	LQLEOHA7080800PBI0

OHS Range - Tech Comparison

The Entry-Level



The compact power



The Versatile Workhorse



Model	OHS15	OHS20	OHS40
Stirring quantity max [L / H ₂ O]	20L	25L	40L
Speed range [rpm]	50-1000	90-2000	50-1000
Max Torque [N-cm]	15Ncm	20Ncm	40Ncm
Max Viscosity	8000mPas	10000mPas	30000mPas
Motor	BLDC	BLDC	BLDC
Power	24V/36W	24V/36W	24V/36W
Change of Rotation Direction	Yes	Yes	Yes
Speed / Timer Display	Digital LED	Digital LED	Digital LED
Impeller Adjustment	Push Through	Push Through	Push Through
Overload Protection	Yes	Yes	Yes
Over Temperature Protection	Yes	Yes	Yes
Auto Resume - Power Interruption	Yes	Yes	Yes
Smart Control Feature	Yes	Yes	Yes
IP Rating	IP54	IP54	IP54
Chuck range diameter [mm]	1-10mm	1-10mm	1-10mm
Timer	1-99 min OR Continuous	1-99 min OR Continuous	1-99 min OR Continuous
Dimensions (L x W x H) [mm]	176X173X79	176X173X79	176X173X79
Item Code	LQLEOHS015020PR000	LQLEOHS020025PR000	LQLEOHS040040PR000

The Efficient Performer



The Industrial Strength



The Ultimate Powerhouse



Model	OHS50	OHS75	OHS100
Stirring quantity max [L / H ₂ O]	50L	75L	100L
Speed range [rpm]	60-2000	60-2000	60-1300
Max Torque [N-cm]	50Ncm	75Ncm	100Ncm
Max Viscosity	30000mPas	50000mPas	70000mPas
Motor	BLDC	BLDC	BLDC
Power	24V/72W	24V/72W	24V/72W
Change of Rotation Direction	Yes	Yes	Yes
Speed / Timer Display	Digital LED	Digital LED	Digital LED
Impeller Adjustment	Push Through	Push Through	Push Through
Overload Protection	Yes	Yes	Yes
Over Temperature Protection	Yes	Yes	Yes
Auto Resume - Power Interruption	Yes	Yes	Yes
Smart Control Feature	Yes	Yes	Yes
IP Rating	IP42	IP42	IP42
Chuck range diameter [mm]	1-10mm	1-10mm	1-10mm
Timer	1-99 min OR Continuous	1-99 min OR Continuous	1-99 min OR Continuous
Dimensions (L x W x H) [mm]	102X242X249	102X242X249	102X242X249
Item code	LQLEOHS050050E0000	LQLEOHS075075E0000	LQLEOHS100100E0000

Mechanical Accessories

Stands/clamps / chuck



Only H-stand

LQLEOHA5045102HS01
500X450X1020mm



Plate Stand

PlateStand 220X320 mm
Rod 560mm - (5L)
LQLEOHA2232560PS01
Rod 800 mm- (5L)
LQLEOHA2232800PS02
Rod 1000 mm - (5L)
LQLEOHA2232100PS03



Boss Head Clamp

Boss head clamp for H stand
LQLEOHA00001BHCH01
Boss head clamp for Plate stand PROHS
LQLEOHA00001BHCPR0
Boss head clamp for Plate / H stand PR OHS
LQLEOHA00001BHCPR1



Key Chuck

LQLEOHA00000HKC001



Keyless Chuck

LQLEOHA00000HKC002



Collet Chuck

LQLEOHA00000HKC003



Chuck Cover

LQLEOHA00000HKC004

BOROSIL[®]
Scientific

1101, Crescenzo, G-Block, Opp. MCA Club,
Bandra Kurla Complex, Bandra (E), Mumbai - 400 051, India.
T +91 22 6740 6300 F +91 22 6740 6514
E bsl@borosil.com W www.borosilscientific.com
For export enquires write us at bsl.exports@borosil.com

PROUDLY MADE IN 
india



SMART

RUGGED

PRACTICAL